



# CERRUTI

[www.cerrutimacchineagricole.it](http://www.cerrutimacchineagricole.it)

## TURBONEVE BIG 620 HY



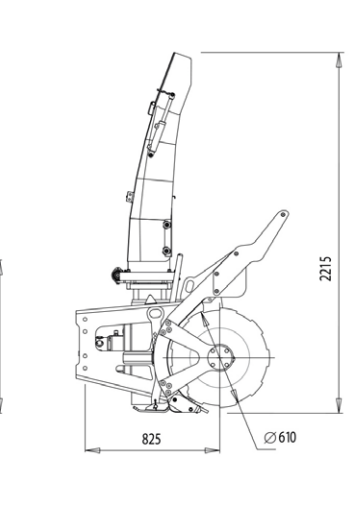
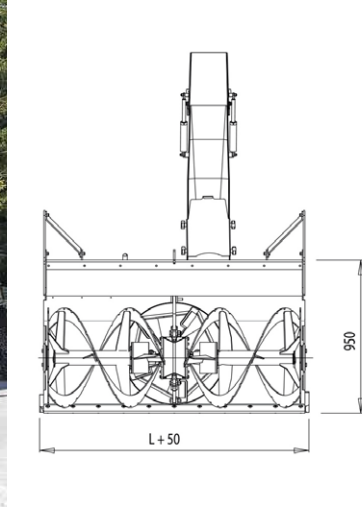

Turbina da neve a doppio stadio, adatta a mezzi di notevoli dimensioni ed elevata capacità oleodinamica, tipo pale gommate, mezzi telescopici, porta-attrezzi, skid-loader. Personalizzabile con una vasta gamma di accessori, idonei a un mezzo sgombraneve di tipo professionale.

#### CARATTERISTICHE STANDARD

- Altezza di lavoro 950 mm
- Azionata con motore idraulico
- Predisposizione per collegamento con piastra
- Ventola II stadio Ø 620 mm
- Eliche frontali autoportanti Ø 610 mm con rompighiaccio
- Camino ribaltabile

#### APPLICAZIONI A RICHIESTA

- Camino a regolazione totale in ferro zincato
- Limitatori di sicurezza sulle eliche frontali
- Bascula con oscillazione idraulica
- Rulli di appoggio in materiale sintetico

MODELLO	PORTATA OLIO	LAGHEZZA LAVORO	PESO
L 1600	l/min 120/160	1600 mm	610 kg
L 1800	l/min 130/160	1800 mm	670 kg
L 2000	l/min 140/160	2000 mm	730 kg
L 2200	l/min 140/160	2200 mm	790 kg
L 2300	l/min 140/200	2300 mm	820 kg
L 2500	l/min 140/200	2500 mm	850 kg



Double stage snow blower, suitable for vehicles of considerable size and high hydraulic capacity, such as wheel loaders, telescopic vehicles, tool carriers, skid-loaders. Customizable with a wide range of accessories, for a professional snow attachment.

#### STANDARD FEATURES

- Working height 950 mm
- Operated with hydraulic motor
- Predisposition for connection with plate
- Fan stage II Ø 620 mm
- Self-supporting front propellers Ø 610 mm with icebreaker
- Tippable chute

#### APPLICATIONS ON REQUEST

- Fully adjustable chute in galvanized iron
- Safety limiters on the front augers
- Swinging connection with hydraulic control
- Hand-crank adjustable roller skid for sport fields

MODEL	OIL CAPACITY	WORKING WIDTH	WEIGHT
L 1600	l/min 120/160	1600 mm	610 kg
L 1800	l/min 130/160	1800 mm	670 kg
L 2000	l/min 140/160	2000 mm	730 kg
L 2200	l/min 140/160	2200 mm	790 kg
L 2300	l/min 140/200	2300 mm	820 kg
L 2500	l/min 140/200	2500 mm	850 kg



Fraise à neige à double étage, adaptée pour des engins de grandes dimensions et ayant des grandes capacités hydrauliques, tels que chargeuses sur pneus, engins télescopiques, porte-outils, chargeuses. Il est possible de la personnaliser avec une grande gamme d'accessoires, adaptés pour une souffleuse à neige à usage professionnel.

#### CARACTÉRISTIQUES STANDARDS

- Hauteur d'exploitation 950 mm
- Actionnée par un moteur hydraulique
- Équipement pour raccordement avec plaque
- Ventilateur II étages Ø 620 mm
- Hélices frontales autoportantes Ø 610 mm avec brise-glace
- Goulotte d'éjection rabattable

#### APPLICATIONS SUR DEMANDE

- Goulotte d'éjection à réglage total en fer galvanisé
- Limiteurs de sécurité sur les hélices frontales
- Bascule avec oscillation hydraulique
- Rouleaux d'appui en matière synthétique

MODÈLE	DÉBIT D'HUILE	LARGEUR D'EXPLOITATION	POIDS
L 1600	l/min 120/160	1600 mm	610 kg
L 1800	l/min 130/160	1800 mm	670 kg
L 2000	l/min 140/160	2000 mm	730 kg
L 2200	l/min 140/160	2200 mm	790 kg
L 2300	l/min 140/200	2300 mm	820 kg
L 2500	l/min 140/200	2500 mm	850 kg



Doppelstufige Schneefräse, für besonders große Fahrzeuge mit hoher öldynamischer Leistung geeignet, wie z.B. Radlader, Teleskopfahrzeuge, Gerätefahrzeuge, Kompaktlader. Durch eine große Auswahl an Zubehör kann die Schneefräse auf die persönlichen für den professionellen Einsatz benötigten Anforderungen abgestimmt werden.

#### SERIENMÄSSIGE AUSSTATTUNG

- Räumhöhe 950 mm
- Antrieb durch Hydraulikmotor
- Vorbereitet für Anbauplatten
- Flügelrad der 2. Stufe Ø 620 mm
- Selbsttragende Frontschnecken Ø 610 mm mit Eisbrecher
- Kamin umklappbar

#### SONDERAUSSTATTUNG

- Kamin stufenlos einstellbar aus verzinktem Eisen
- Automatische Nockenschaltkupplung auf den Frontschnecken
- Niveaueingleich mit hydraulischer Steuerung
- Einstellbare Kunststoffwalzen für Rasenflächen

MODELL	ÖLDURCHFLOSS	RÄUMBREITE	GEWICHT
L 1600	l/min 120/160	1600 mm	610 kg
L 1800	l/min 130/160	1800 mm	670 kg
L 2000	l/min 140/160	2000 mm	730 kg
L 2200	l/min 140/160	2200 mm	790 kg
L 2300	l/min 140/200	2300 mm	820 kg
L 2500	l/min 140/200	2500 mm	850 kg

**CERRUTI srl**

Via Statale 27/H • 14033 Castell'Alfero • Asti • Italia • T. +39 0141 296957 • F. +39 0141 276915  
 info@cerrutimacchineagricole.it • [www.cerrutimacchineagricole.it](http://www.cerrutimacchineagricole.it)