

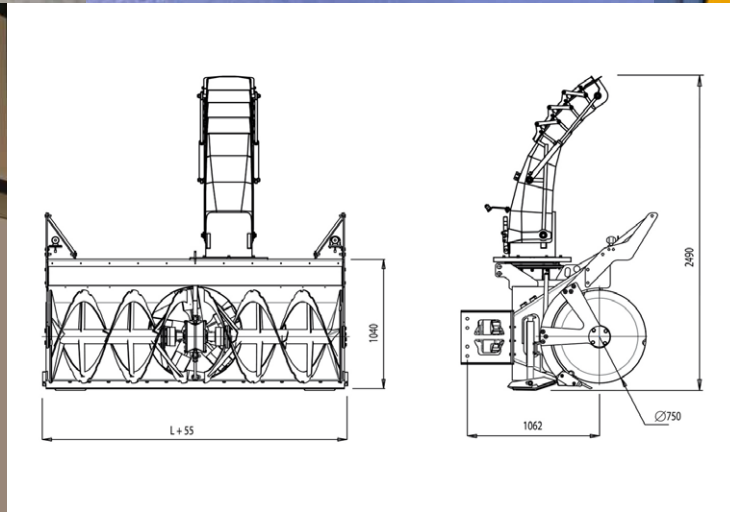

[www.cerrutimacchineagricole.it](http://www.cerrutimacchineagricole.it)

**TURBONEVE**  
**BIG 750 HY**

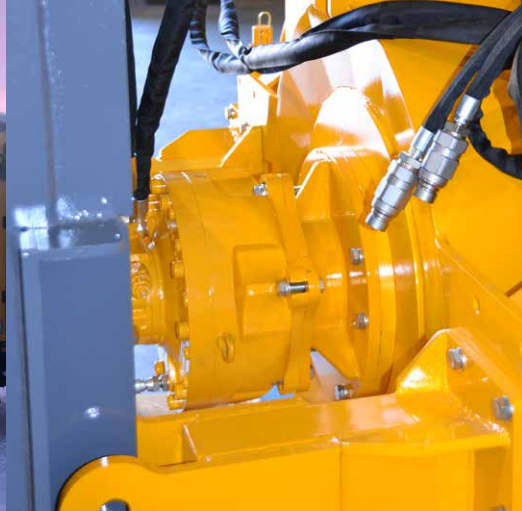



Turbina da neve a doppio stadio di tipo professionale, adatta a mezzi di notevoli dimensioni ed elevate capacità oleodinamiche, tipo pale gommate, porta-attrezzi e skid-loader. Questo modello viene fornito super accessorizzato.

#### CARATTERISTICHE STANDARD

- Altezza lavoro 1040 mm
- Predisposto per collegamento con piastra
- Ventola II stadio Ø 750 mm
- Eliche frontali con rompighiaccio e limitatori automatici di sicurezza Ø 750 mm
- Rotazione camino e regolazione deflettore idraulico
- Camino a regolazione totale ribaltabile in ferro zincato

#### APPLICAZIONI A RICHIESTA

- Bascula a controllo idraulico
- Parallelogramma di sollevamento idraulico
- Prolunghe camino da 500 o 750 mm per carico neve su camion
- Elettrovalvola di commutazione a 6 vie

MODELLO	PORTATA O/U	LARGHEZZA LAVORO	PESO
L 2000	l/min 150/200	2000 mm	940 kg
L 2200	l/min 150/200	2200 mm	1030 kg
L 2400	l/min 160/200	2400 mm	1110 kg
L 2500	l/min 160/200	2500 mm	1160 kg
L 2600	l/min 160/200	2600 mm	1200 kg



Professional double stage snow blower, suitable for vehicles of considerable size and high hydraulic capacity, such as wheel loaders, tool carriers and skid-loaders. This model is supplied full optional.

#### STANDARD FEATURES

- Working height 1040 mm
- Prepared for connection with plate
- Fan II stage Ø 750 mm
- Front propellers with icebreaker and automatic safety limiters Ø 750 mm
- Chimney rotation and hydraulic deflector adjustment
- Fully adjustable tilting chimney in galvanized iron

#### APPLICATIONS ON REQUEST

- Swinging connection with hydraulic control
- Hydraulic lifting parallelogram
- 500 or 750 mm chimney extensions for snow loading on trucks
- 6-way commutation solenoid valve

MODEL	OIL CAPACITY	WORKING WIDTH	WEIGHT
L 2000	l/min 150/200	2000 mm	940 kg
L 2200	l/min 150/200	2200 mm	1030 kg
L 2400	l/min 160/200	2400 mm	1110 kg
L 2500	l/min 160/200	2500 mm	1160 kg
L 2600	l/min 160/200	2600 mm	1200 kg



Fraise à neige à double étage à usage professionnel, adaptée pour des engins de grandes dimensions et ayant des grandes capacités hydrauliques, tels que chargeuses sur pneus, porte-outils et chargeuses. Ce modèle est fourni avec de nombreux accessoires.

#### CARACTÉRISTIQUES STANDARDS

- Hauteur d'exploitation 1040 mm
- Équipée pour raccordement avec plaque
- Ventilateur II étages Ø 750 mm
- Hélices frontales avec brise-glace et limiteurs automatiques de sécurité Ø 750 mm
- Rotation hydraulique de la goulotte d'éjection et réglage hydraulique du déflecteur
- Goulotte d'éjection à réglage total rabattable en fer galvanisé

#### APPLICATIONS SUR DEMANDE

- Bascule à contrôle hydraulique
- Parallelogramme de levage hydraulique
- Rallonges de goulotte d'éjection de 500 ou 700 mm pour le chargement de la neige sur camion
- Électrovanne de commutation à 6 voies

MODÈLE	DÉBIT D'HUILE	LARGEUR D'EXPLOITATION	POIDS
L 2000	l/min 150/200	2000 mm	940 kg
L 2200	l/min 150/200	2200 mm	1030 kg
L 2400	l/min 160/200	2400 mm	1110 kg
L 2500	l/min 160/200	2500 mm	1160 kg
L 2600	l/min 160/200	2600 mm	1200 kg



Doppelstufige Schneefräse für den professionellen Einsatz, geeignet für besonders große Fahrzeuge mit hoher öldynamischer Leistung, wie Radlader, Gerätefahrzeuge und Kompaktlader. Dieses Modell wird bereits mit diverser Zubehör ausgestattet geliefert.

#### SERIENMÄSSIGE AUSSTATTUNG

- Räumhöhe 1040 mm
- Vorbereitet für Anbauplatte
- Flügelrad der 2. Stufe Ø 750 mm
- Frontschnecken Ø 750 mm mit automatischer Nockenschaltkupplung und Eisbrecher
- Kaminschwengung und Wurfweitenverstellung hydraulisch
- Kamin stufenlos einstellbar und umklappbar

#### SONDERAUSSTATTUNG

- Niveaueausgleich mit hydraulischer Steuerung
- Parallelogramm mit hydraulischer Aushebung
- Kaminverlängerung von 500 oder 750 mm zum Schneeverladen
- 6-Wege-Umschaltventil

MODELL	ÖLDURCHFLOSS	RÄUMBREITE	GEWICHT
L 2000	l/min 150/200	2000 mm	940 kg
L 2200	l/min 150/200	2200 mm	1030 kg
L 2400	l/min 160/200	2400 mm	1110 kg
L 2500	l/min 160/200	2500 mm	1160 kg
L 2600	l/min 160/200	2600 mm	1200 kg

**CERRUTI srl**

Via Statale 27/H • 14033 Castell'Alfero • Asti • Italia • T. +39 0141 296957 • F. +39 0141 276915  
 info@cerrutimacchineagricole.it • [www.cerrutimacchineagricole.it](http://www.cerrutimacchineagricole.it)