

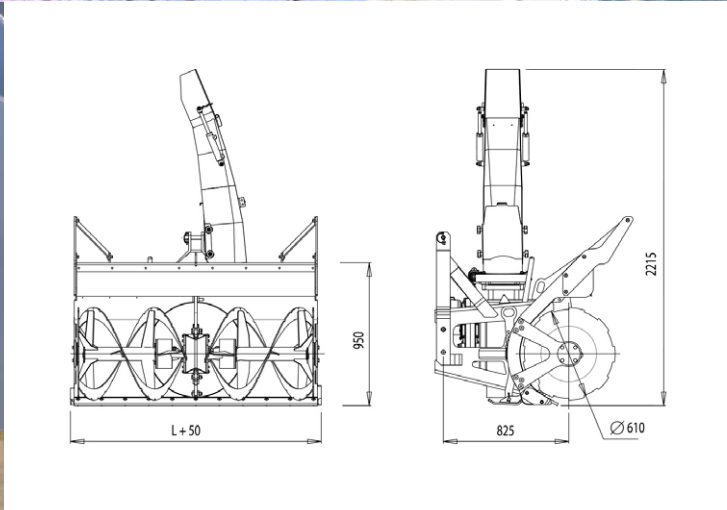

www.cerrutimacchineagricole.it

TURBONEVE BIG 620





Turbina da neve a doppio stadio di tipo professionale, adatta a trattori di medie e grandi dimensioni, con potenze fra 60 e 150 Hp. Può essere personalizzata con un'ampia gamma di accessori.

CARATTERISTICHE STANDARD

- Altezza lavoro 950 mm
- Attacco a 3 punti
- Ventola II stadio Ø 620 mm
- Eliche frontali con rompighiaccio Ø 610 mm
- Rotazione camino e regolazione deflettore idraulico
- Camino ribaltabile in ferro zincato

APPLICAZIONI A RICHIESTA

- Scatola ingranaggi a 3 assi per montaggio su PTO frontale o posteriore
- Camino ribaltabile a regolazione totale in ferro zincato
- Limitatori di sicurezza automatici sulle eliche frontali
- Prolunghe camino da 500 o 750 mm per carico neve su camion

MODELLO	POTENZA	LAGHEZZA LAVORO	PESO
L 1600	60/150 Hp	1600 mm	590 kg
L 1800	70/150 Hp	1800 mm	630 kg
L 2000	70/150 Hp	2000 mm	680 kg
L 2200	90/150 Hp	2200 mm	760 kg
L 2300	90/150 Hp	2300 mm	780 kg
L 2500	100/150 Hp	2500 mm	850 kg



Professional double stage snow blower, suitable for medium and large tractors, with power between 60 and 150 Hp. It can be customized with a wide range of accessories.

STANDARD FEATURES

- Working height 950 mm
- 3 point attack
- II stage fan Ø 620 mm
- Front propellers with icebreaker Ø 610 mm
- Chimney rotation and hydraulic deflector adjustment
- Folding chimney in galvanized iron

APPLICATIONS ON REQUEST

- 3-axis gearbox for front or rear PTO mounting
- Fully adjustable tilting chimney in galvanized iron
- Automatic safety limiters on the front propellers
- 500 or 750 mm chimney extensions for snow loading on trucks

MODEL	POWER	WORKING WIDTH	WEIGHT
L 1600	60/150 Hp	1600 mm	590 kg
L 1800	70/150 Hp	1800 mm	630 kg
L 2000	70/150 Hp	2000 mm	680 kg
L 2200	90/150 Hp	2200 mm	760 kg
L 2300	90/150 Hp	2300 mm	780 kg
L 2500	100/150 Hp	2500 mm	850 kg



Fraise à neige à double étage à usage professionnel, adaptée pour des tracteurs de moyennes et grandes dimensions, d'une puissance comprise entre 60 et 150 Hp. Il est possible de la personnaliser grâce à une large gamme d'accessoires.

CARACTÉRISTIQUES STANDARDS

- Hauteur d'exploitation 950 mm
- Attelage 3 points
- Ventilateur II étages Ø 620 mm
- Hélices frontales avec brise-glace Ø 610 mm
- Rotation hydraulique de la goulotte d'éjection et réglage hydraulique du déflecteur
- Goulotte d'éjection rabattable en fer galvanisé

APPLICATIONS SUR DEMANDE

- Boîtier engrenages à 3 axes pour montage sur PdF avant ou arrière
- Goulotte d'éjection rabattable à réglage total en fer galvanisé
- Limites de sécurité automatiques sur les hélices frontales
- Rallonges de goulotte d'éjection de 500 ou 700 mm pour le chargement de la neige sur camion

MODÈLE	PUISSANCES	LARGEUR D'EXPLOITATION	POIDS
L 1600	60/150 Hp	1600 mm	590 kg
L 1800	70/150 Hp	1800 mm	630 kg
L 2000	70/150 Hp	2000 mm	680 kg
L 2200	90/150 Hp	2200 mm	760 kg
L 2300	90/150 Hp	2300 mm	780 kg
L 2500	100/150 Hp	2500 mm	850 kg



Doppelstufige Schneefräse für den professionellen Einsatz, geeignet für Traktoren mittlerer und hoher Leistungen von 60 bis 150 PS. Die Schneefräse kann durch eine große Auswahl an Zubehör auf den persönlichen Bedarf ausgestattet werden.

SERIENMÄSSIGE AUSSTATTUNG

- Räumhöhe 950 mm
- 3-Punkt-Anschluss
- Flügelrad der 2. Stufe Ø 620 mm
- Frontschnecken Ø 610 mm mit Eisbrecher
- Kaminschwengung und Wurfweitenverstellung hydraulisch
- Kamin umklappbar aus verzinktem Eisen

SONDERAUSSTATTUNG

- Dreiaxsiges Getriebe mit zwei Zapfwelleingängen für Front- und Heckanbau
- Kamin stufenlos einstellbar aus verzinktem Eisen
- Automatische Nockenschaltkupplung auf den Frontschnecken
- Kaminverlängerung 500 oder 750 mm zum Schneeverladen

MODELL	LEISTUNGSBEDARF	RÄUMBREITE	GEWICHT
L 1600	60/150 Hp	1600 mm	590 kg
L 1800	70/150 Hp	1800 mm	630 kg
L 2000	70/150 Hp	2000 mm	680 kg
L 2200	90/150 Hp	2200 mm	760 kg
L 2300	90/150 Hp	2300 mm	780 kg
L 2500	100/150 Hp	2500 mm	850 kg

CERRUTI srl

Via Statale 27/H • 14033 Castell'Alfero • Asti • Italia • T. +39 0141 296957 • F. +39 0141 276915
 info@cerrutimacchineagricole.it • www.cerrutimacchineagricole.it